

Exhaust gas outlet options

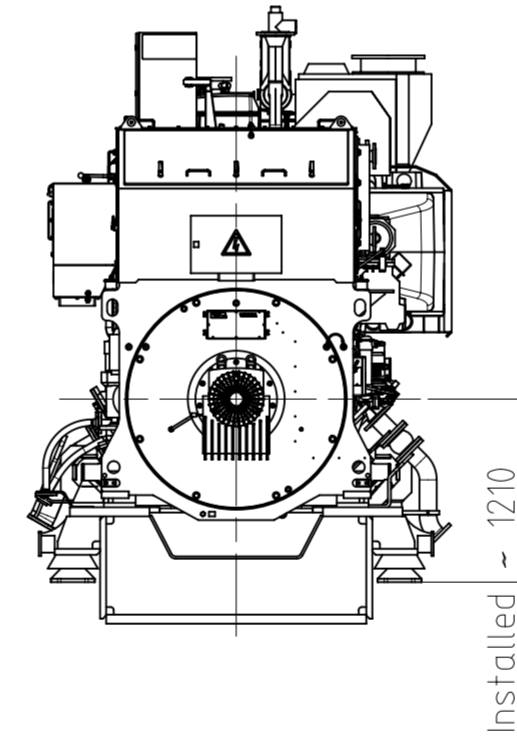
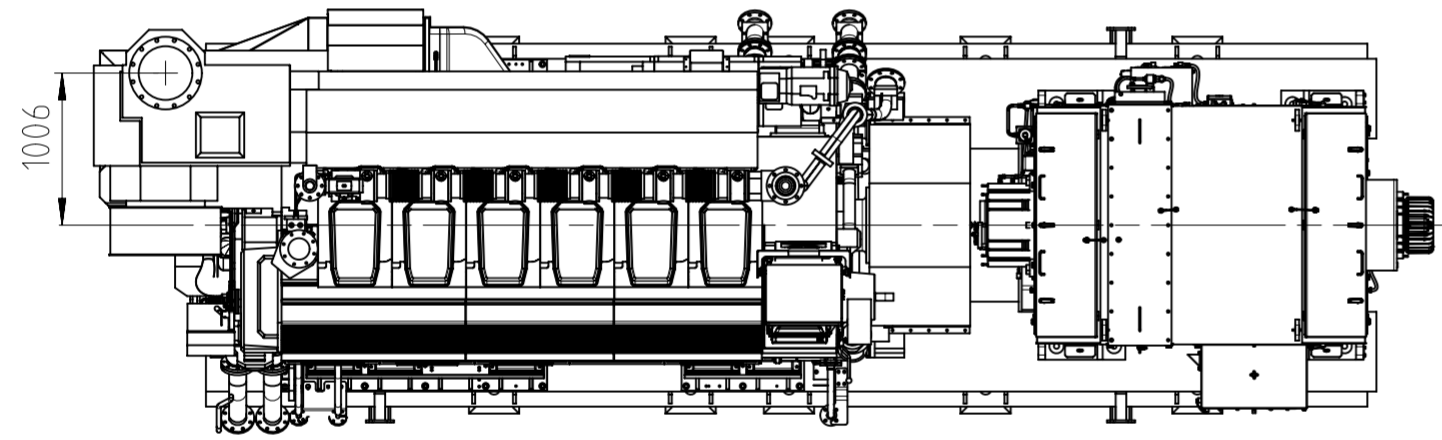
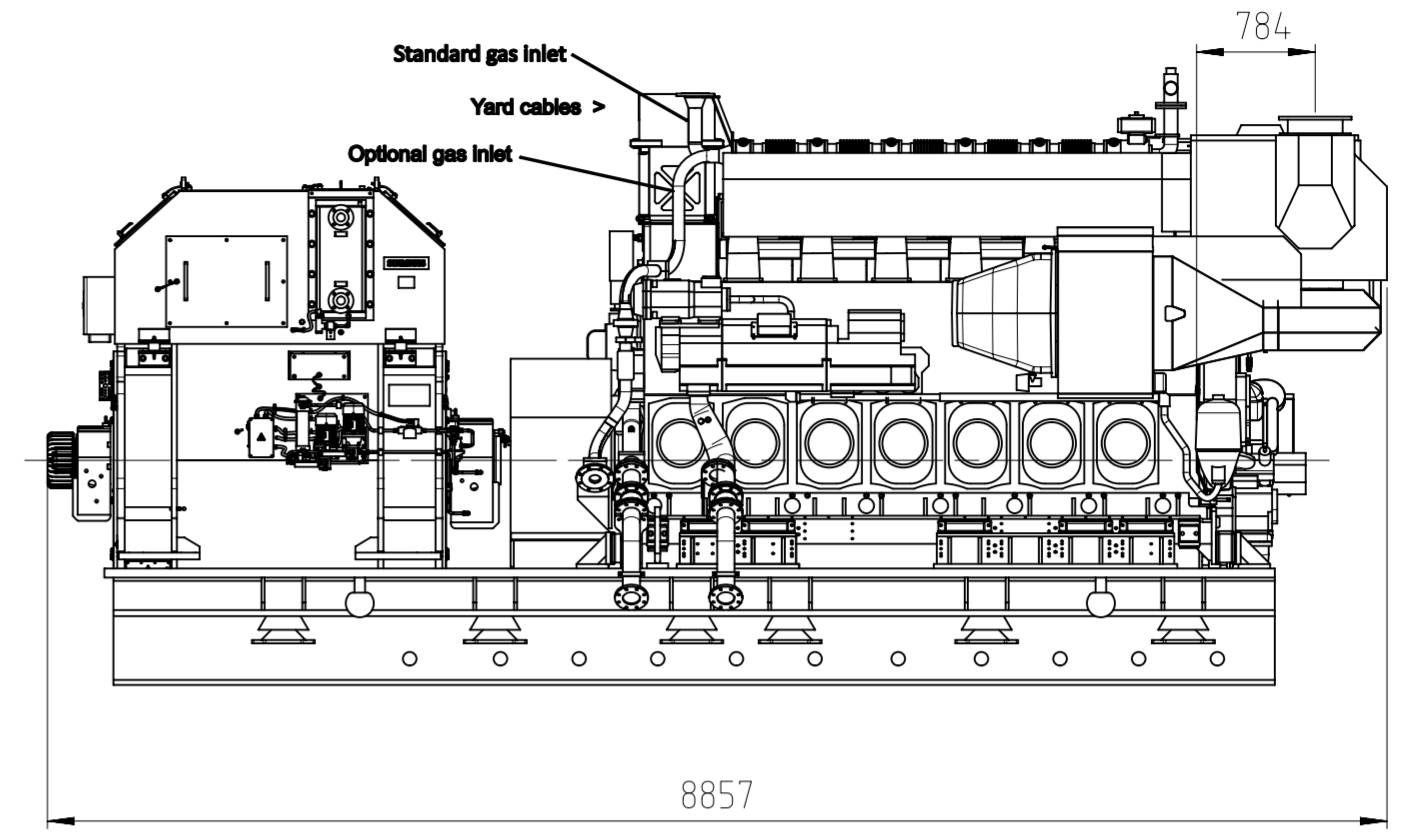
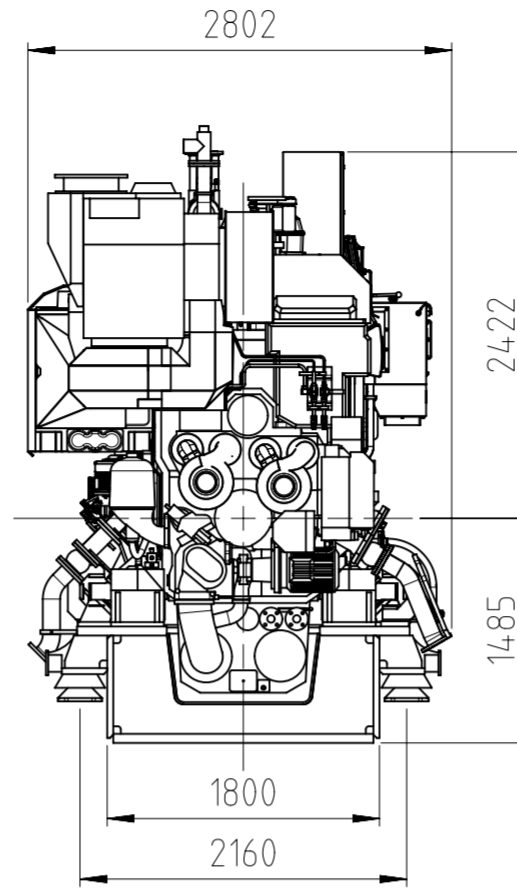
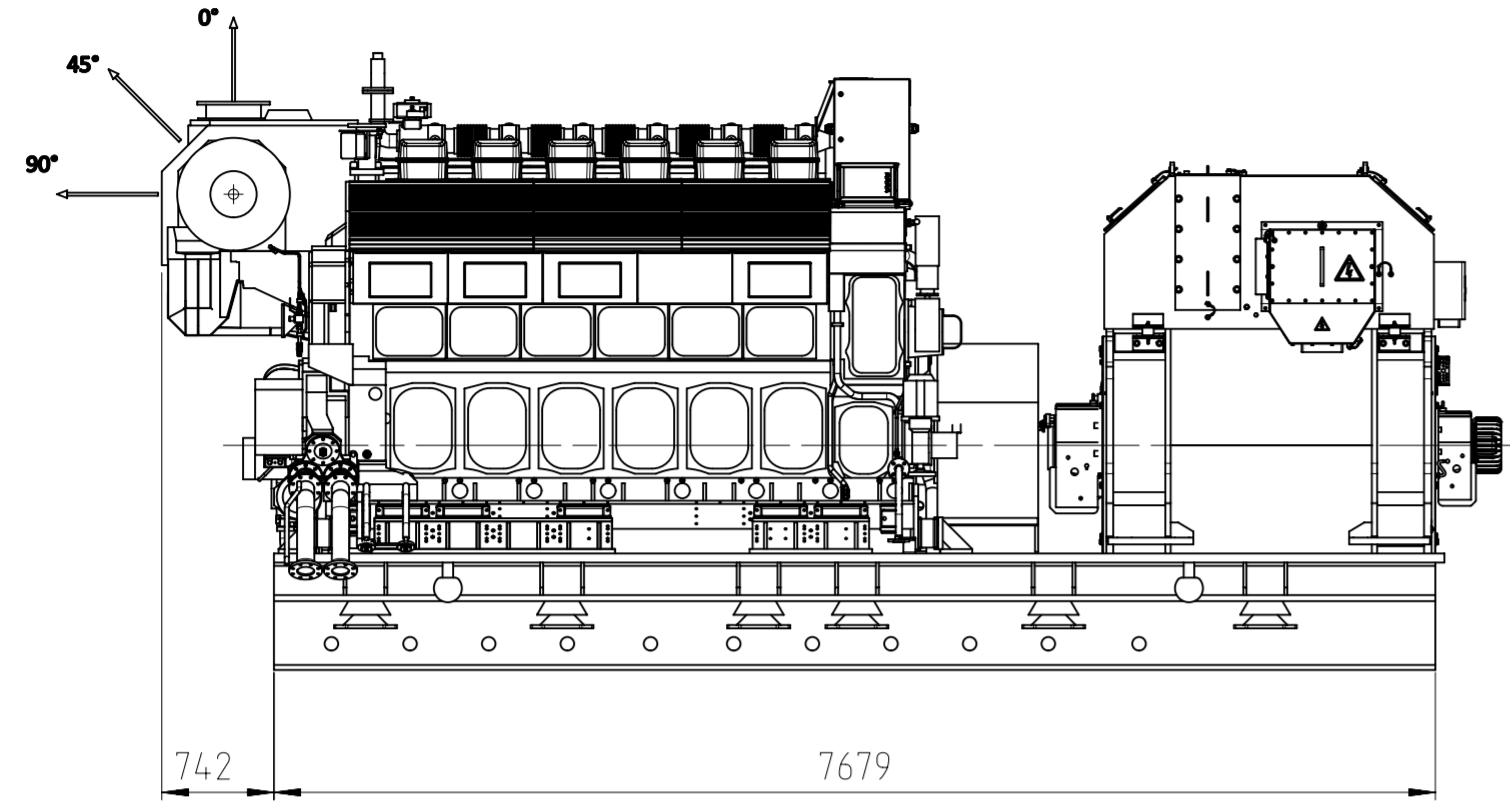

WEIGHTS [kg]	
ENGINE WITH LIQUIDS	35400
COMMON BASE FRAME	18300
GENERATOR	13000
FLEX. COUPLING AND FLYWHEEL	1700
FLEXIBLE MOUNTING	3300
TOTAL WEIGHT	71700

The drawing is only for guidance.  
 Dimensions are preliminary and will change depending on final selection of generator and flexible coupling.

Service spaces see drawing DAAF070676

REV.	DATE	MADE	APPVD.	MEMO NO.	EXPLANATION
B	23.11.2021	DKL004	MTU009	(N-A191499)	Gas connection from above marked as standard
A	31.5.2021	AEK006	MTU009	(N-A178798)	Updated to C design stage

	Product W6L34DF	Outline drawing Dual fuel generating set	
	Double flexible mounting		
Units	mm kg	NX	Basic Material
Made	8.6.2017	btu004	Tuori
Chkd	28.06.2017	dkl004	Klemets
Appd	31.07.2017	mtu009	Södö
Scale	1:40	Size	A2
Design Group	58E0	Page	1/1
Material ID		Drawing ID	DAAF380656
Net Weight		Drawing Rev	B