

Direction of exhaust gas outlet:

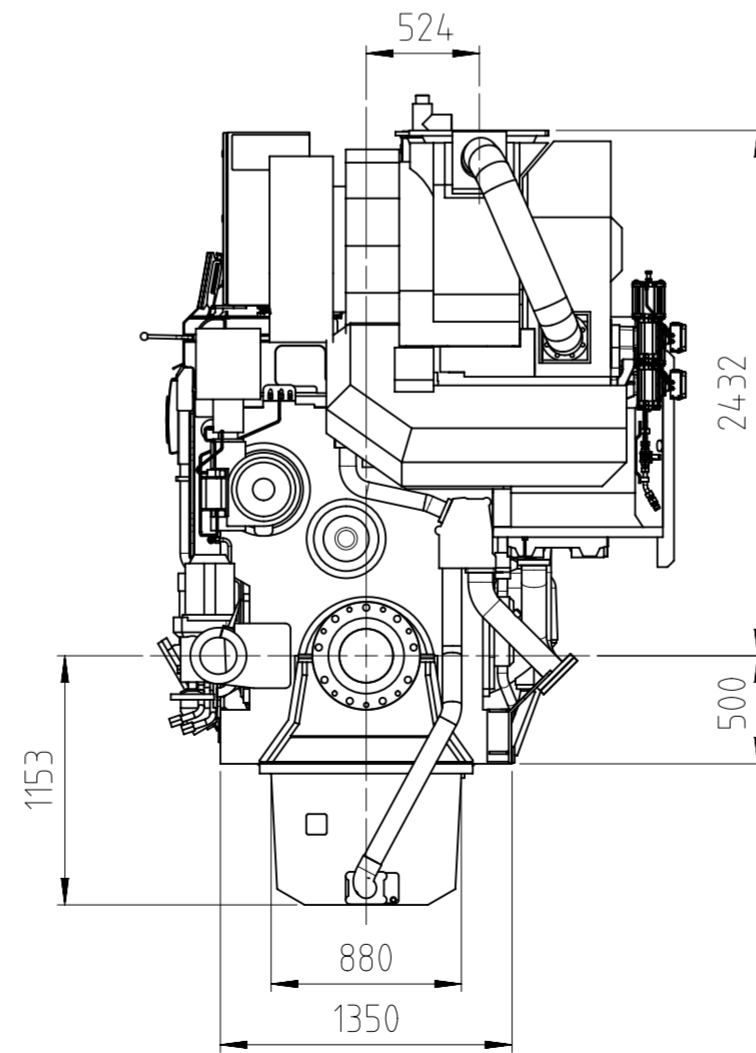
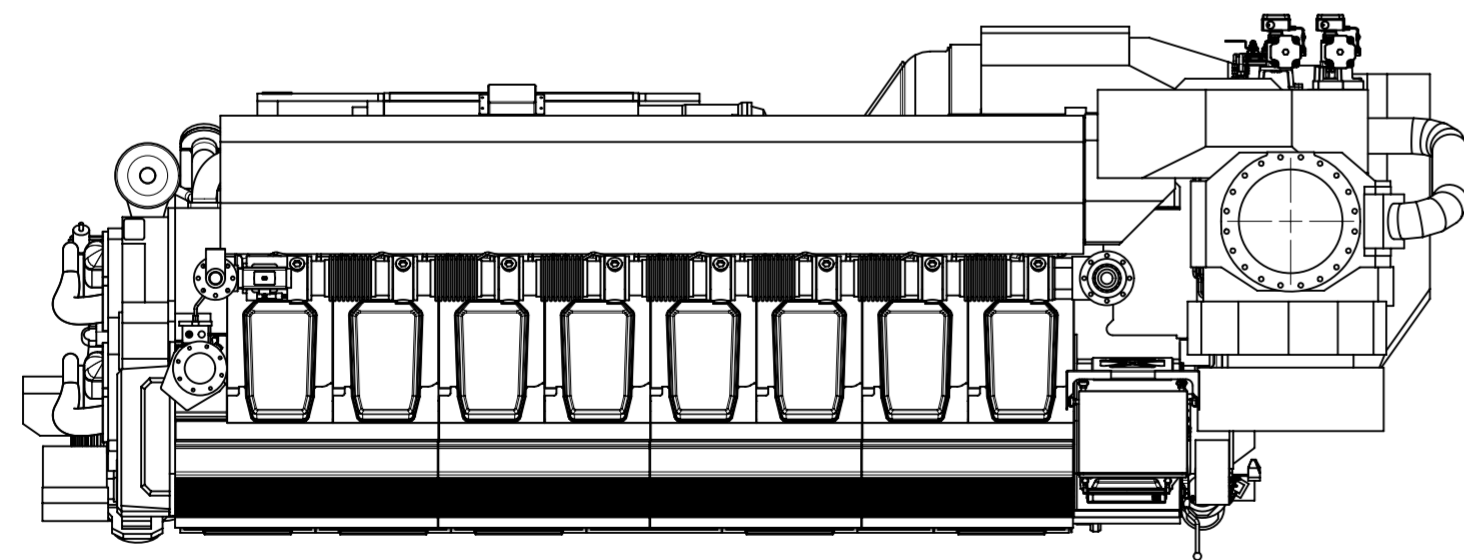
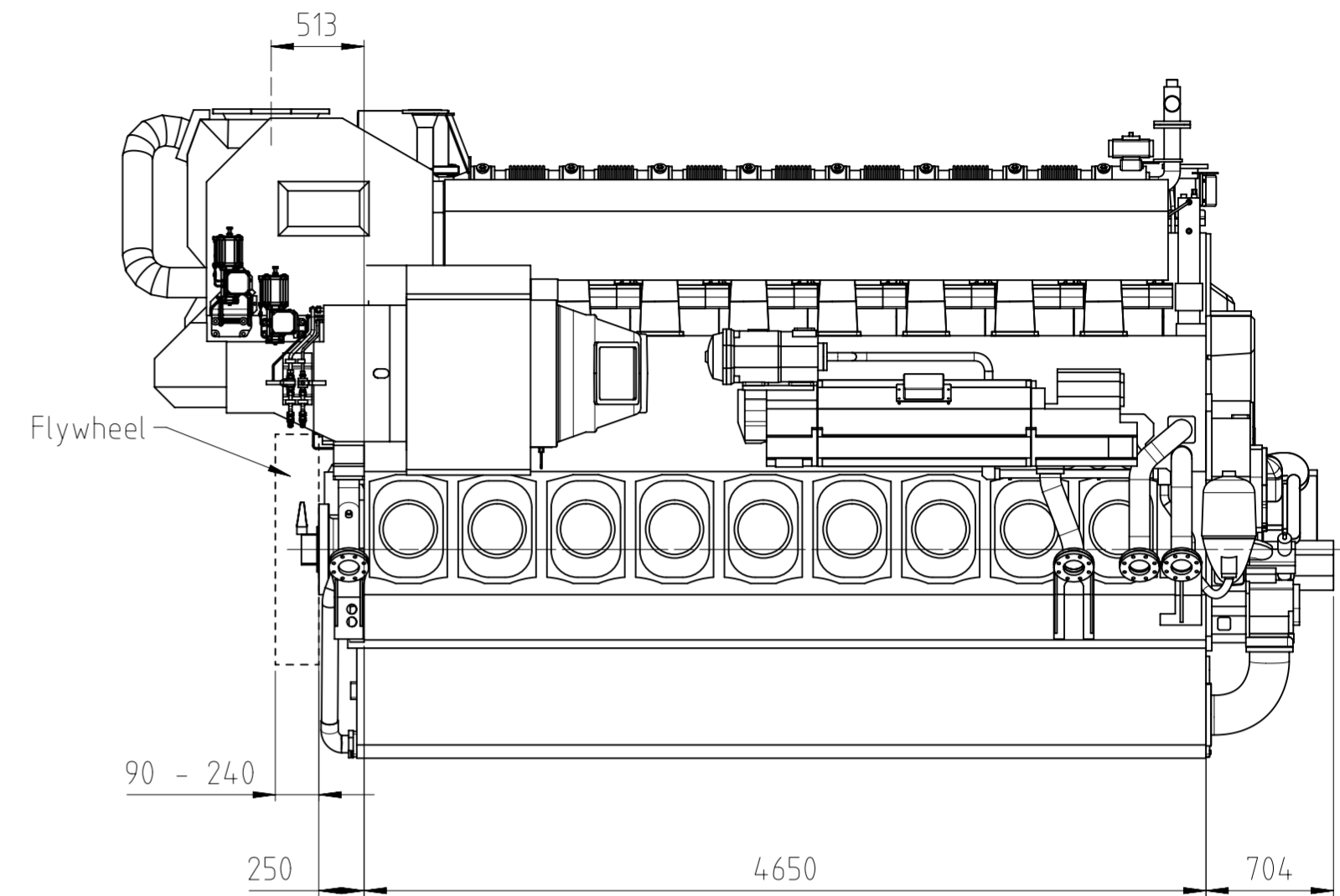
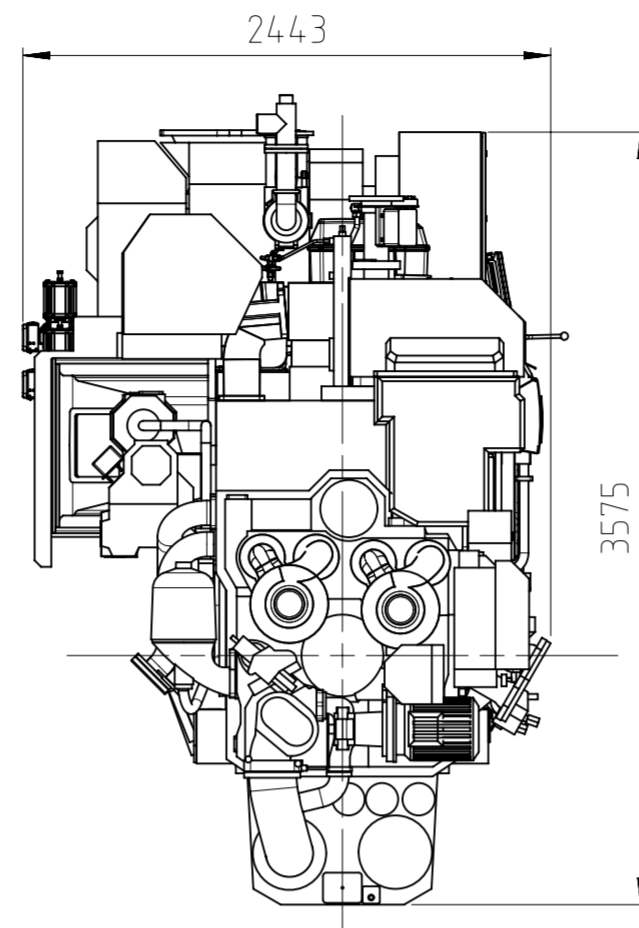
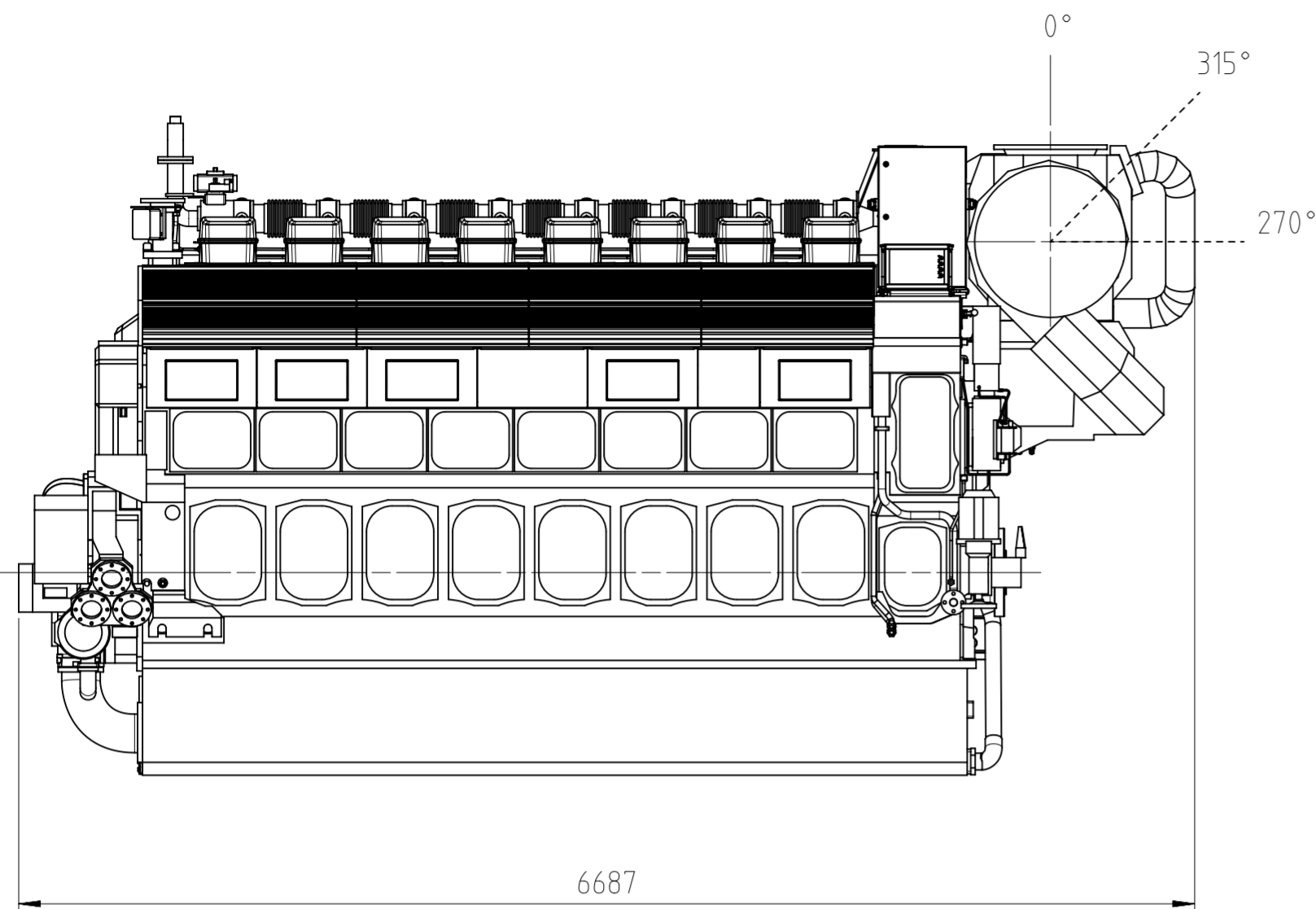

WEIGHTS w/o FLYWHEEL [kg]	
ENGINE WEIGHT	42000
OIL	1700
WATER	700
TOTAL WEIGHT	44400

TC driving end
Wet sump
Fixed mounting

Service space see drawing DAAF088437

		Product W8L34DF	Outline drawing Dual fuel engine		
Units	mm kg	NX	Basic Material	Net Weight	
Made	14.7.2017	eda016 Danielsson	Scale 1:35	Size A2	Page 1/1
Chkd	16.08.2017	dk1004 Klemets	Design Group	Drawing ID	DAAF382182
Appd	16.08.2017	tve001 Vesterbacka	58E		Drawing Rev A

A	11.6.2021	AEK006	MTU009	(N-A179530)	Updated to C design stage
REV.	DATE	MADE	APPVD.	MEMO NO.	EXPLANATION