

Options for direction
of exhaust gas outlet

0°

315°

270°

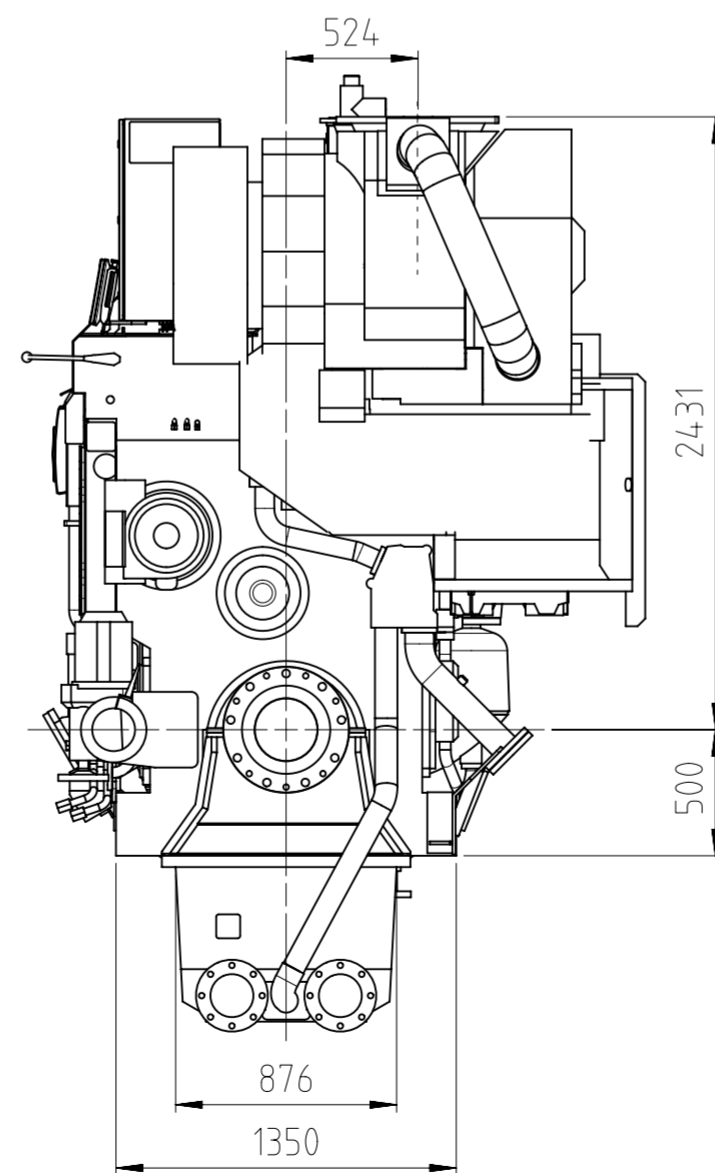
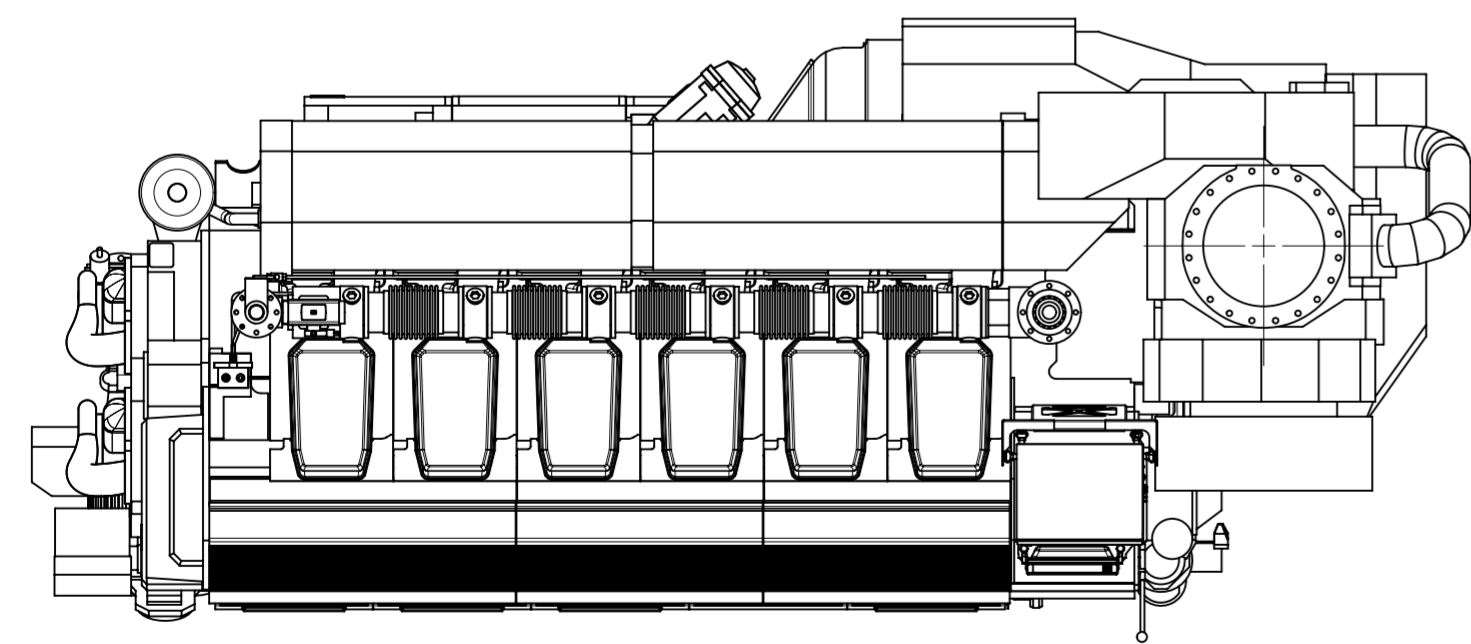
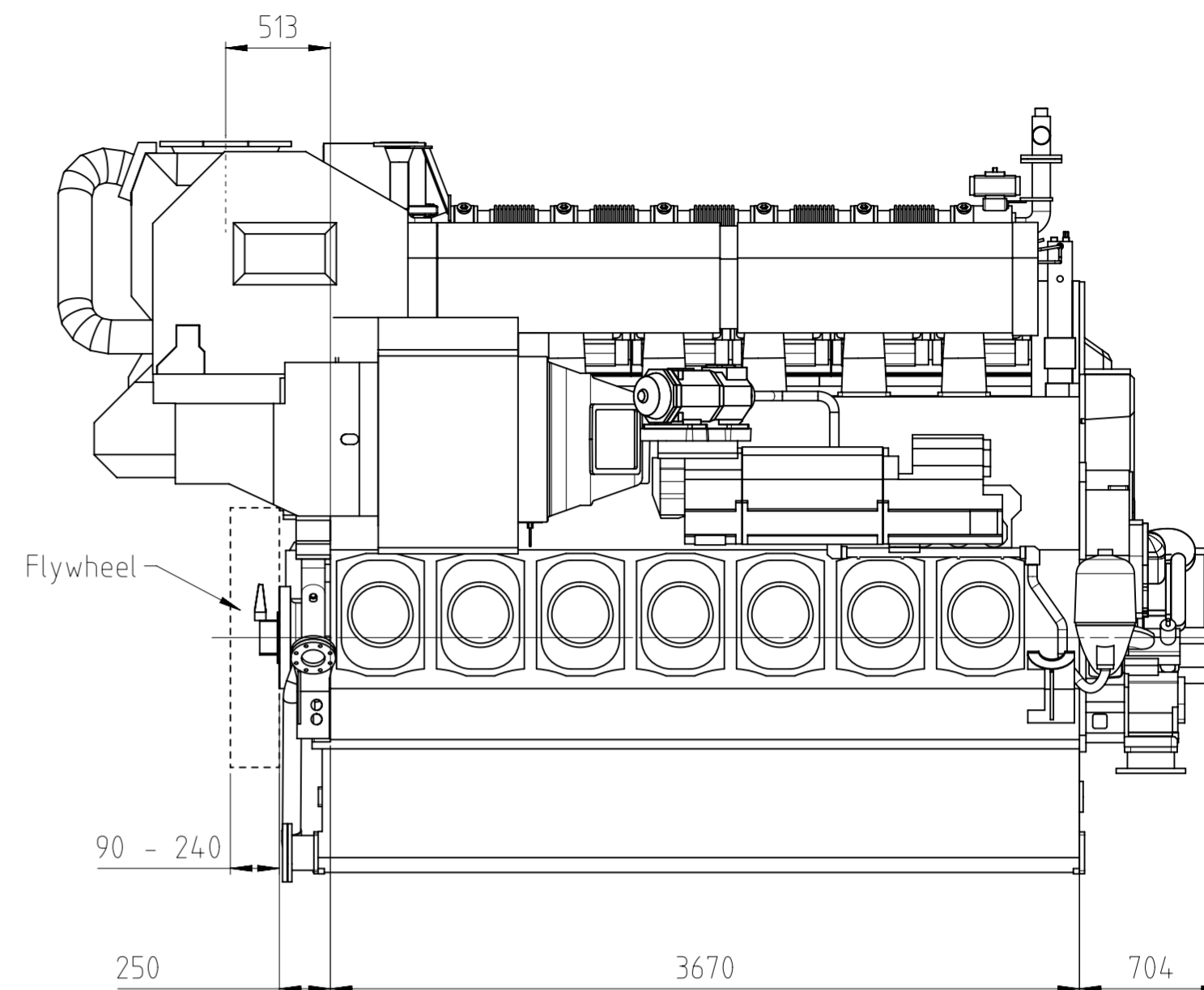
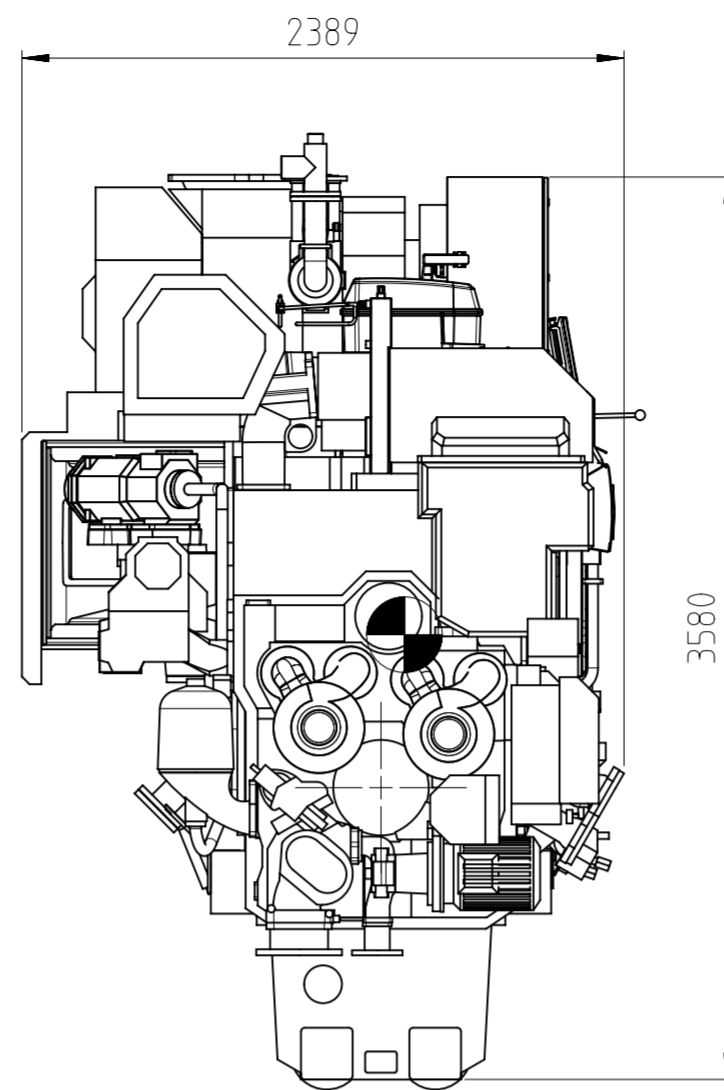
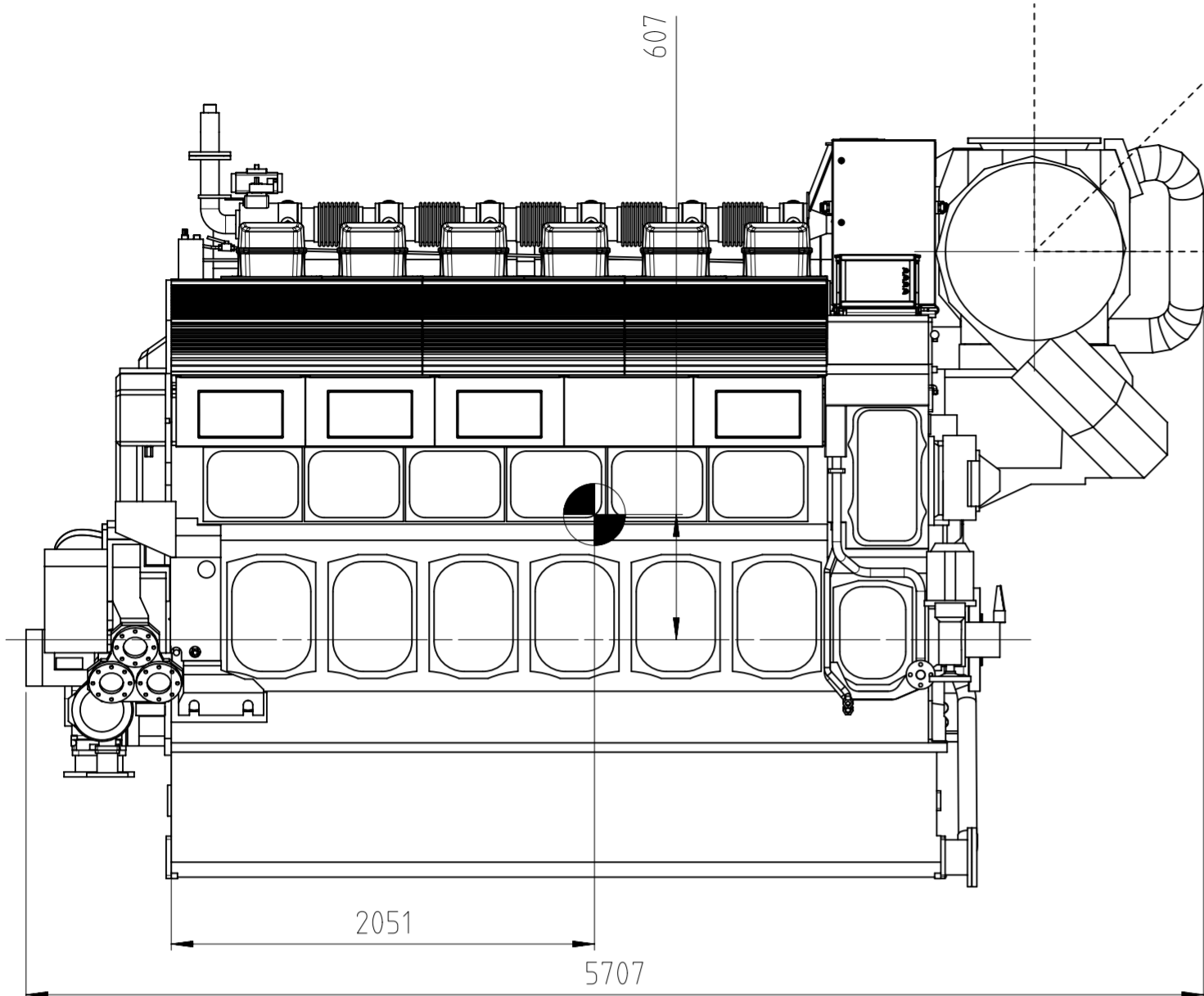

WEIGHTS w/o FLYWHEEL [kg]	
ENGINE WEIGHT	33500
OIL	-
WATER	500
TOTAL WEIGHT	34000

TC driving end
Dry sump
Fixed mounting

Service space see drawing DAAF088437

		Product W6L34DF	Outline drawing Dual fuel engine		
Units	mm kg	NX	Basic Material	Net Weight	
Made	7.6.2017	btu004	Tuori	Scale 1:30	Size A2 Page 1/1 Material ID
Chkd	28.06.2017	dk1004 Klemets		Design Group	Drawing ID
Appd	31.07.2017	mtu009 Södo		58E0	DAAF380587
A 7.6.2021 AEK006 MTU009 (N-A178798) Updated to C design stage					Drawing Rev A
REV. DATE MADE APPVD. MEMO NO. EXPLANATION					